

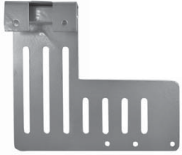

PARTS

A - Bracket (2)



B - T-Shape Extension (2)

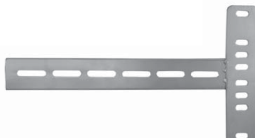

C - Support Bar (2)



HARDWARE

D - 1 3/4" Bolt (4)



E - Washer (8)



F - Wing Nut (4)



G - 1" Bolt (4)



H - 1/2" Bolt (8)



I - Nut (8)



TOOLS REQUIRED -

Phillips Screwdriver

Pliers

UNIVERSAL HEADBOARD/FOOTBOARD BRACKETS

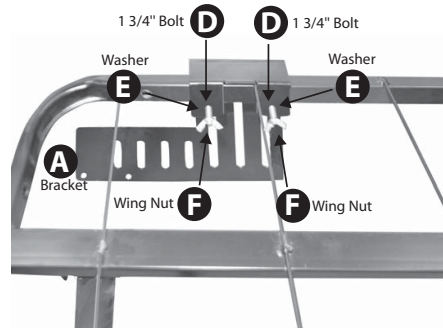

STEP 1: Attach one Headboard/Footboard Bracket (A) to the corner of your Foundation using two 1 3/4" bolts (D) and two washers (E). Secure the bracket in place with two Wing Nuts (F).

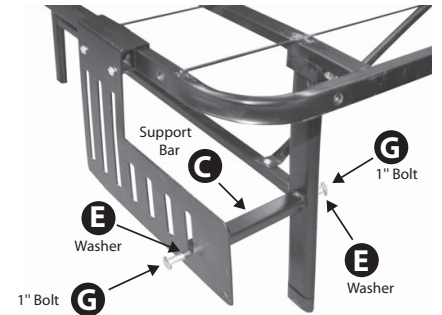

STEP 2: Attach one side of support bar (C) to the leg of your Foundation and the other side to the bracket using the 1" bolts (G) and two washers (E). Secure tightly using a Phillips screwdriver.

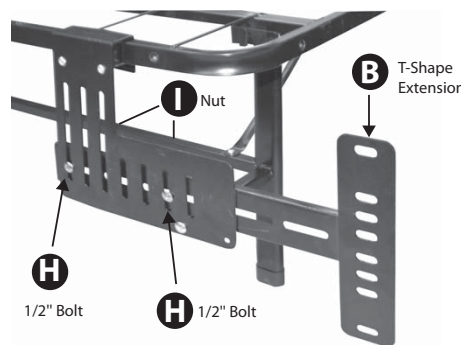

STEP 3: Attach one T-shape extension (B) to the headboard/footboard bracket (A) using two 1/2" Bolts (H) and two nuts (I). Do not tighten at this time.

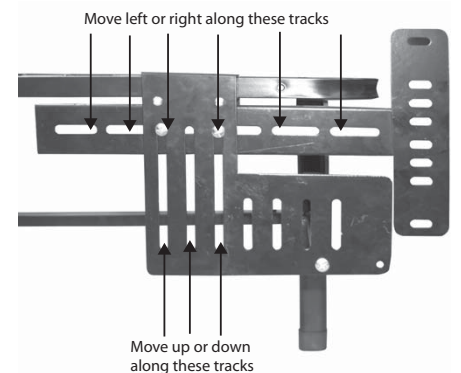

STEP 4: The T-shape extension (B) is able to adjust up or down and left or right in order to accommodate virtually any headboard or footboard. Fully tighten bolts using pliers and phillips screwdriver when you have adjusted to your desired position. Extra 1/2" Bolts (H) and nuts (I) are provided to ensure the extension remains secure.

STEP 5: Repeat steps 1-4 on the opposite side of the Foundation.

STEP 6: Connect the "T" portion of the extension bar to your headboard or footboard. Use the hardware provided with your headboard and/or footboard. Hardware not included with brackets.

